

Scaling of micro-discharges

Dragana Marić¹

Z. Lj. Petrović¹, N. Škoro¹, C.M.O. Mahony², P.D. Maguire²,
M. Radmilović-Rađenović¹ and G. Malović¹

¹Institute of Physics Belgrade, Serbia

²NIBEC, University of Ulster, Northern Ireland, United Kingdom



LABORATORY
FOR GASEOUS
ELECTRONICS
INSTITUTE OF PHYSICS
BELGRADE

Motivation..

MICRODISCHARGES: Si

0.492 mA, 500 Torr Ne

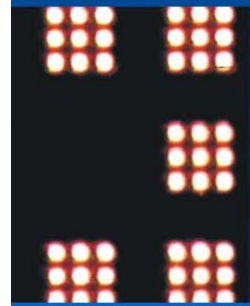
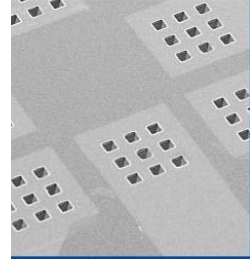

0.492 mA, 500 Torr Ne

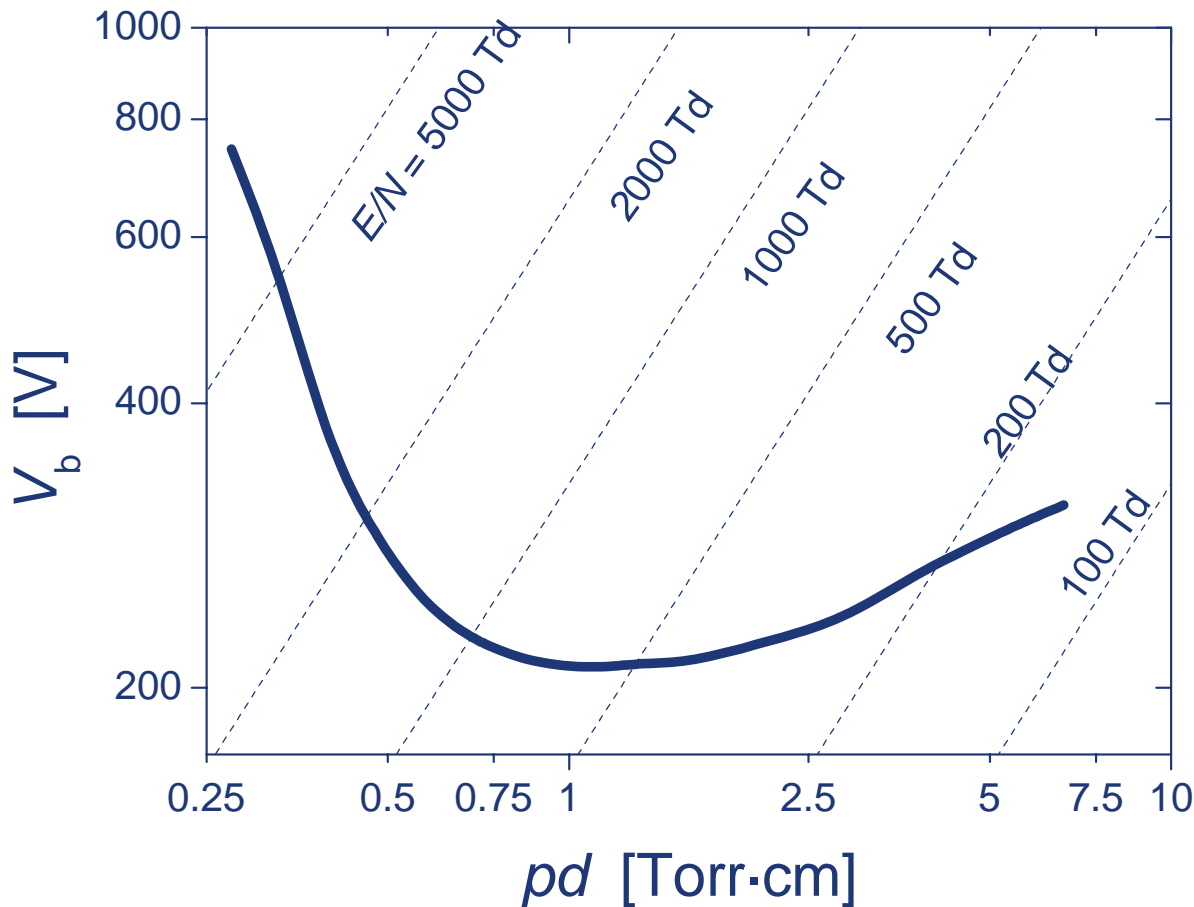

- Applications:**
- DC plasma pressure - us and localized
 - Microhollow
 - Dielectric ba
 - RF discharg
 - Fast materi
 - Large surfac
 - Biophysics:

ATMOSPHERIC
AIR FO

$d = 100 \mu\text{m}$, DC 450 V, 4 mA

Institute of Physics Belgrade, Serbia

ensions
ability,



The issue of scaling

- One of the key issues in transferring our standard knowledge for low pressure non-equilibrium discharges to micro discharges is that of scaling;
- Standard scaling parameters:
 - E/N - electric field to gas number density ratio - proportional to the energy gain from the field between two collisions;
 - pd (Nd) - pressure times the characteristic distance between two electrodes - proportional to the number of collisions;
 - jd^2 (j/p^2) - current density normalized by the geometric dimension to the square- describing the space charge effects;
 - ω/N - frequency normalized by gas number density for rf discharges.



What is expected for micro discharges

- pd , E/N and jd^2 scaling??
- Failure of the scaling can indicate new physics:
 - Heating of the gas
 - Fast neutrals
 - Nonlinear processes (atomic collisions leading to ionization, stepwise excitation, radiation trapping etc.
 - Field emission
 - Quantum effects: tunneling



Breakdown mechanisms

BREAKDOWN MECHANISM	GAP
Townsend Avalanche	$> 5 \mu\text{m}$
Field Emission of electrons	2 nm to $5 \mu\text{m}$
Tunneling of electrons	$< 2 \text{ nm}$

- Important not to ignore field emission or tunneling currents for micro- and nanodevices !



Breakdown voltage in argon discharges

$$\gamma_i(\varepsilon_i) = \frac{0.006 \cdot \varepsilon_i}{1 + (\varepsilon_i / 10)} + 1.05 \cdot 10^{-4} \frac{(\varepsilon_i - 80)^{1.2}}{1 + (\varepsilon_i / 8000)^{1.5}}$$

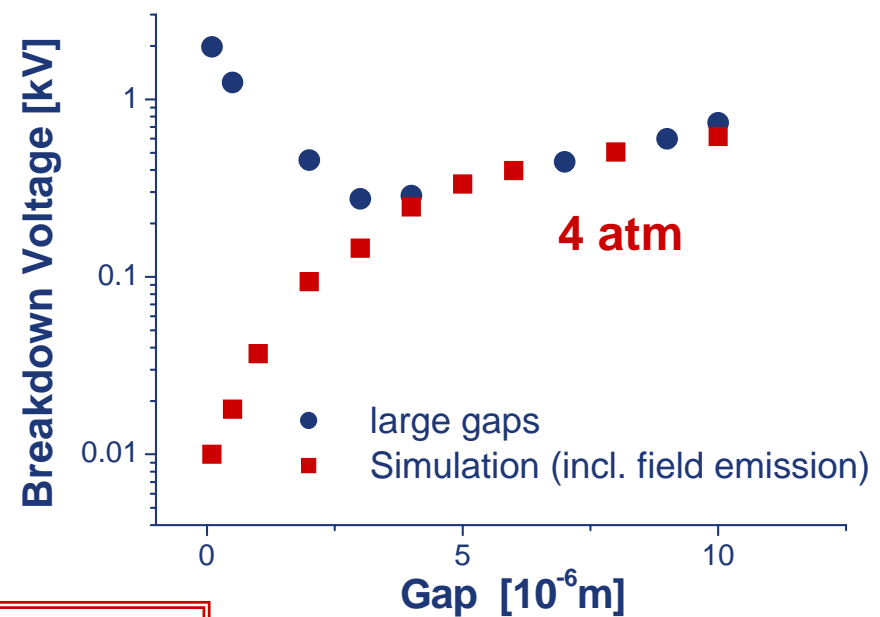
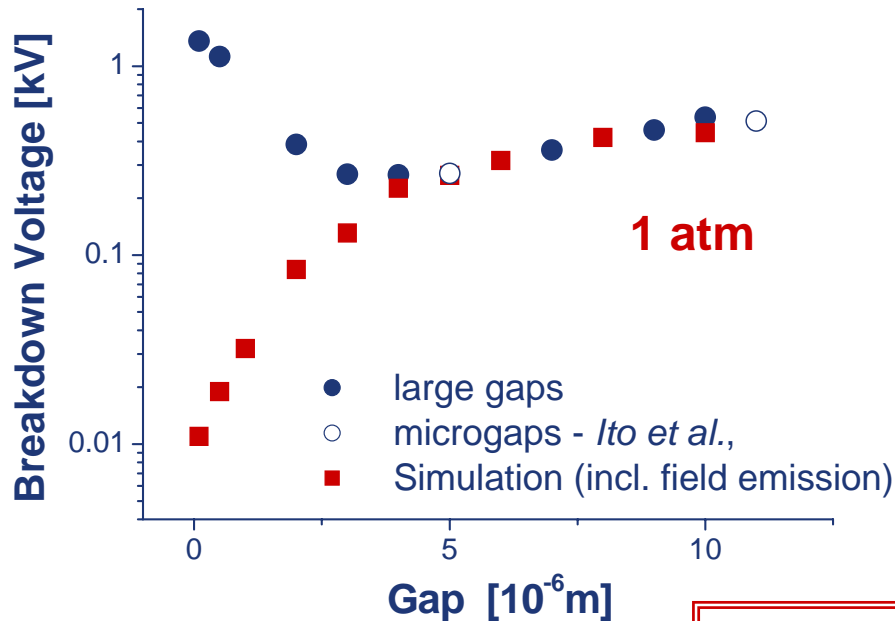

$$\gamma_i = K e^{-B / E}$$

- *W.S. Boyle and P. Kisliuk, Phys. Rev. 97 (1955)*
- *T. Ito, T. Izaki and K. Terashima, Thin Solid Films 386, (2001).*
- *M. Radmilovic-Radjenovic et al., J.Phys.D:Appl.Phys. 38, (2005).*



Scaling of standard size discharges – Volt-Ampere characteristics

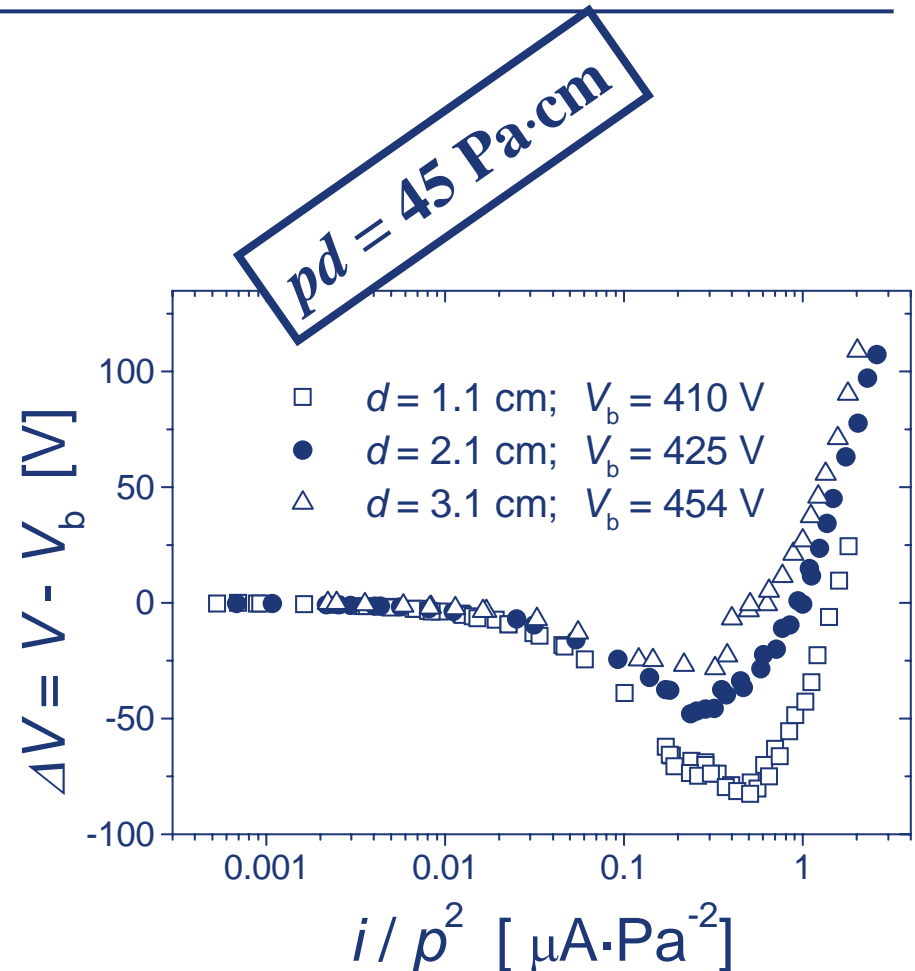
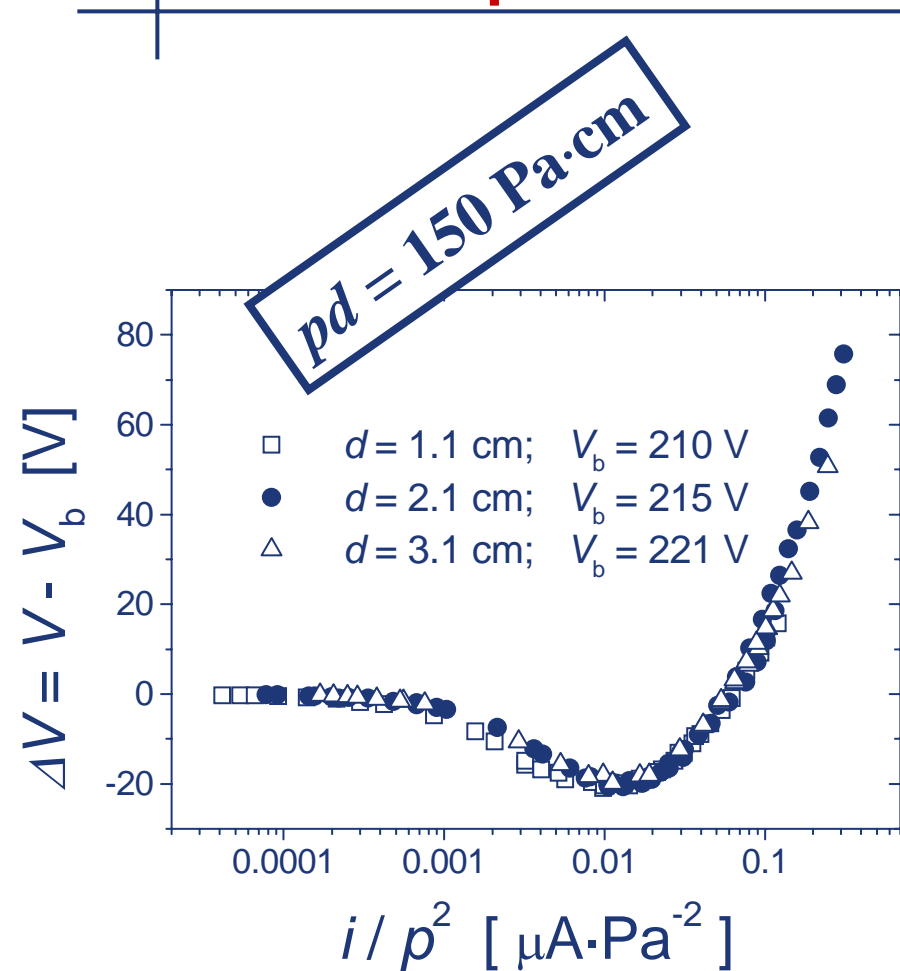

Measurements for micro gaps



- 500-20 μm
- pressure x gap = 0.05 - 5 Torr cm
- diameter = 2mm
- Paschen curves
- V-I characteristics
- oscillations

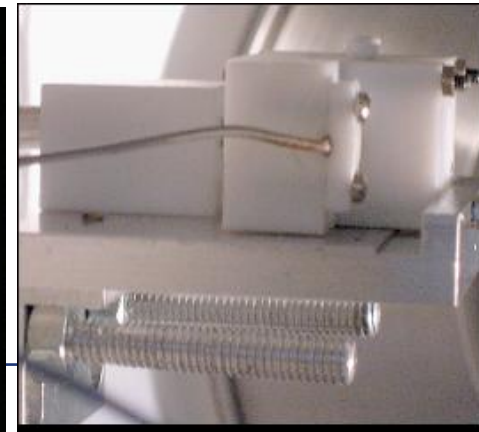
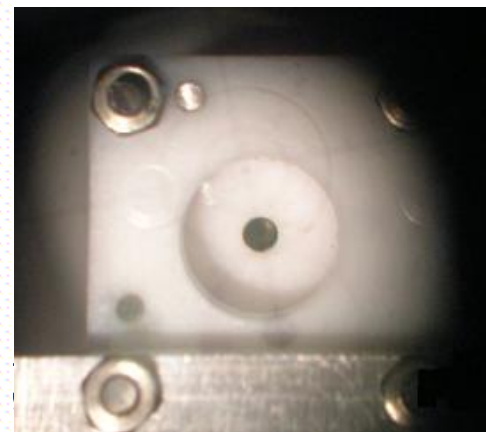
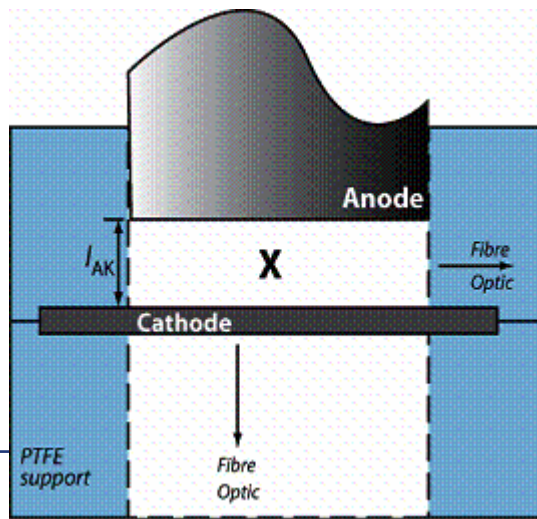
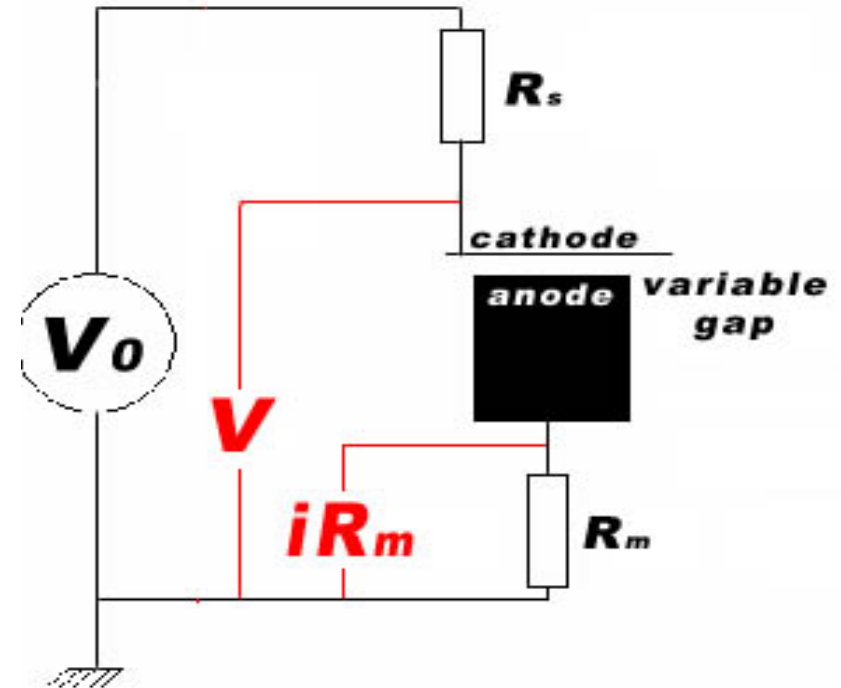

Paschen curves

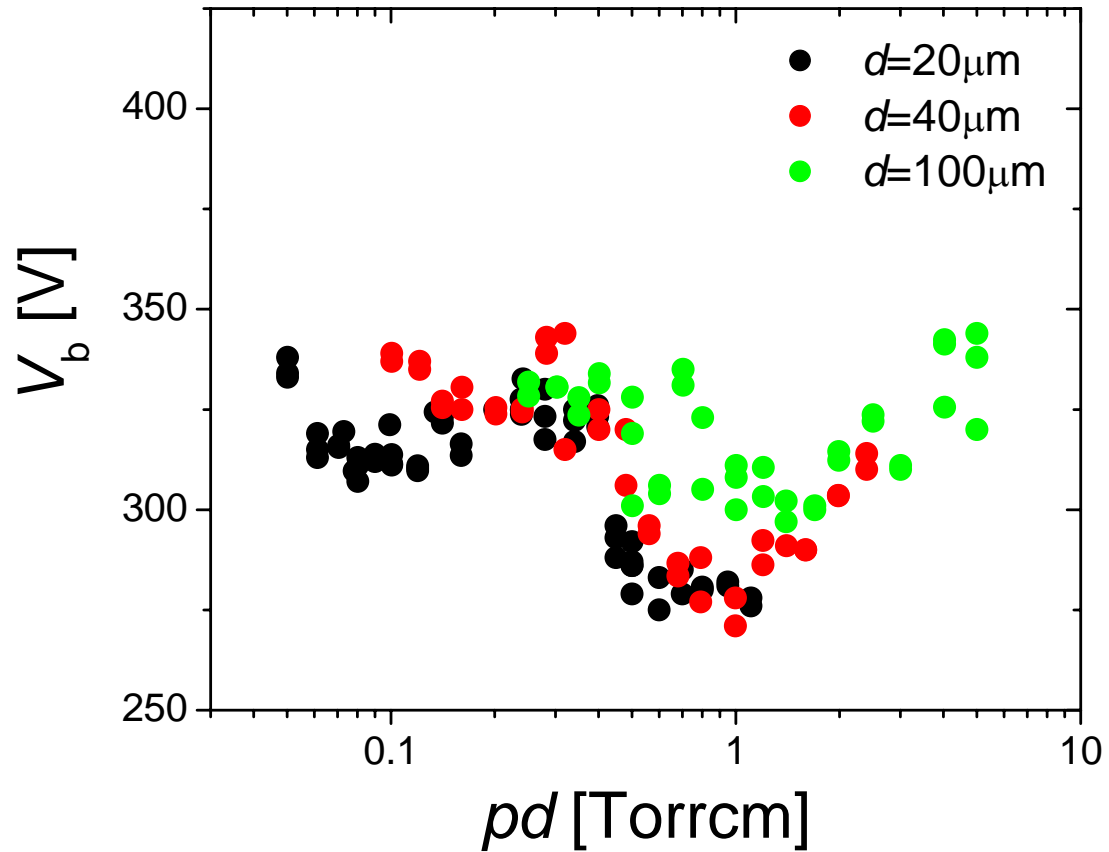
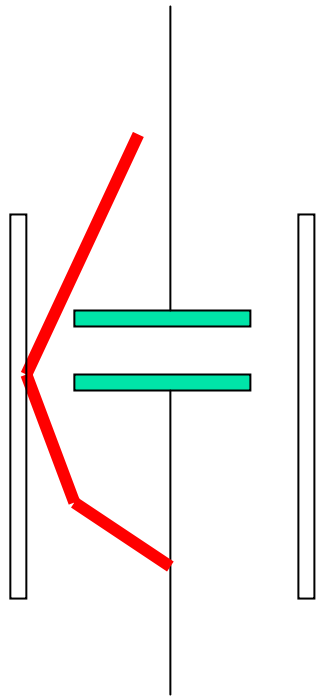

Paschen curves

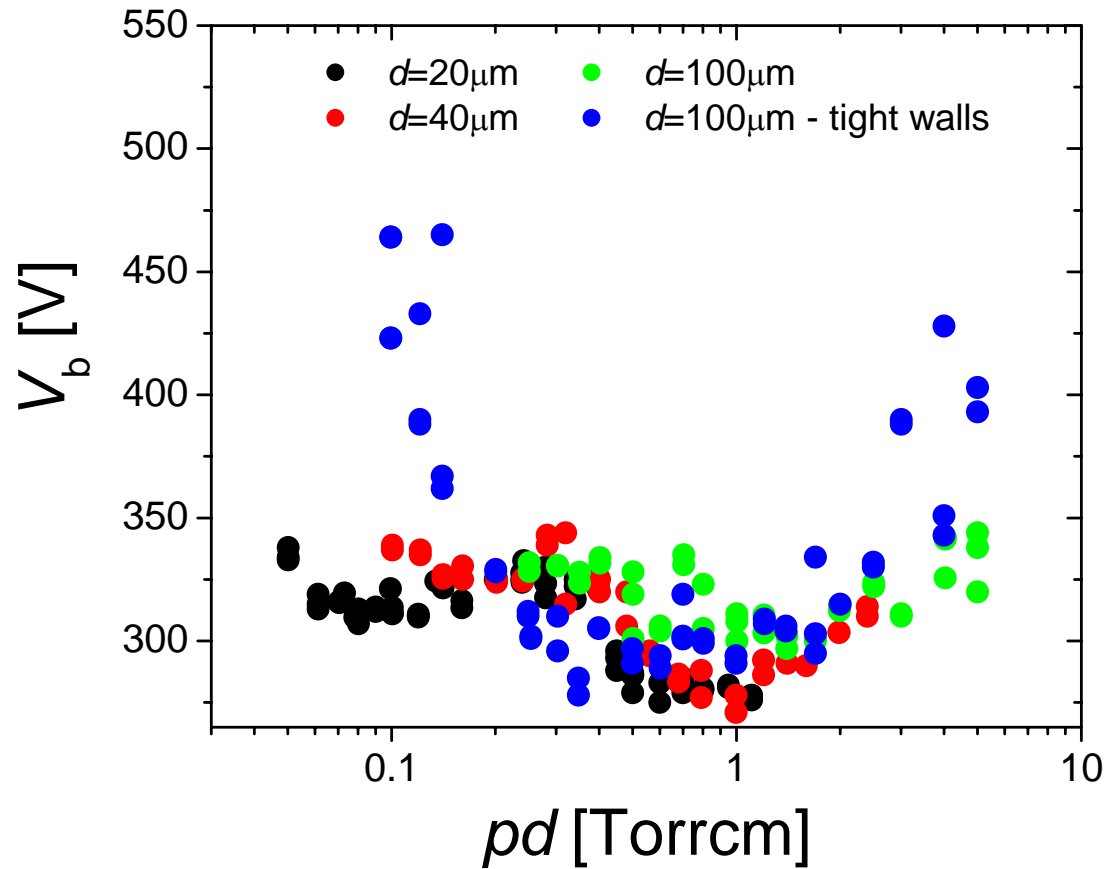
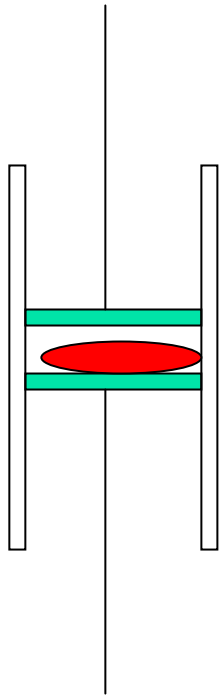

Volt-Ampere characteristics

$pd = 75 \text{ Pa cm}$

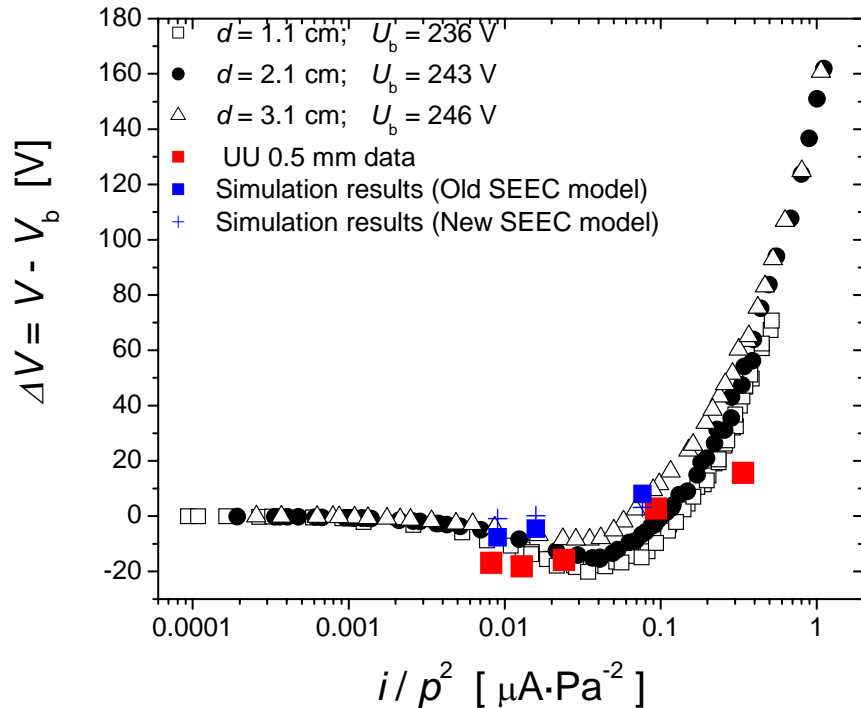

$pd = 150 \text{ Pa cm}$

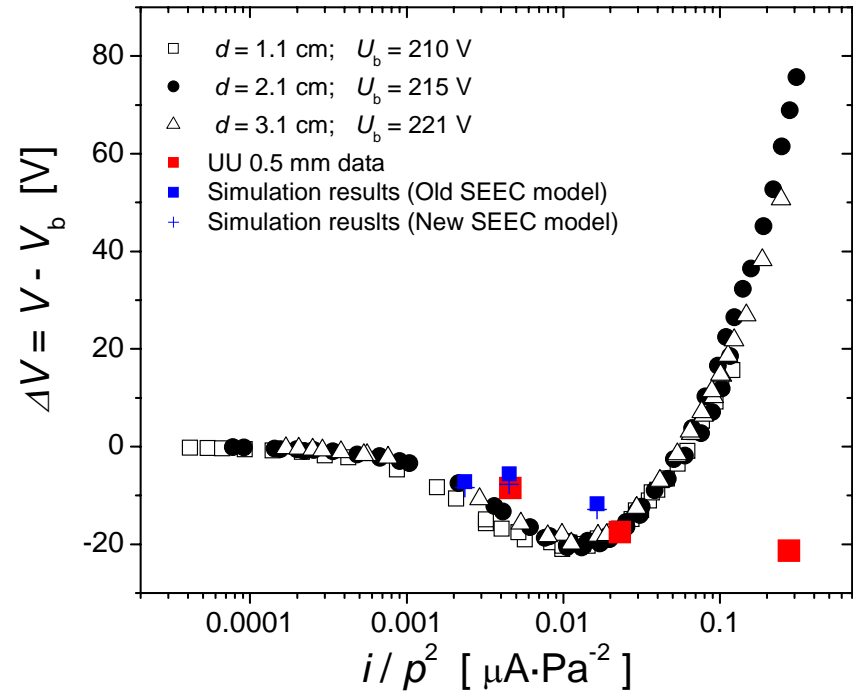

- D. Marić et al

- Z.Lj. Petrović et al

- M. Radmilović-Rađenović, Z.Lj. Petrović, P. Maguire and C. Mahony, 3rd International Workshop on Micorplasmas IWM2006, Greifswald, Germany, (9-11, May 2006).



Volt-Ampere characteristics - smaller gaps

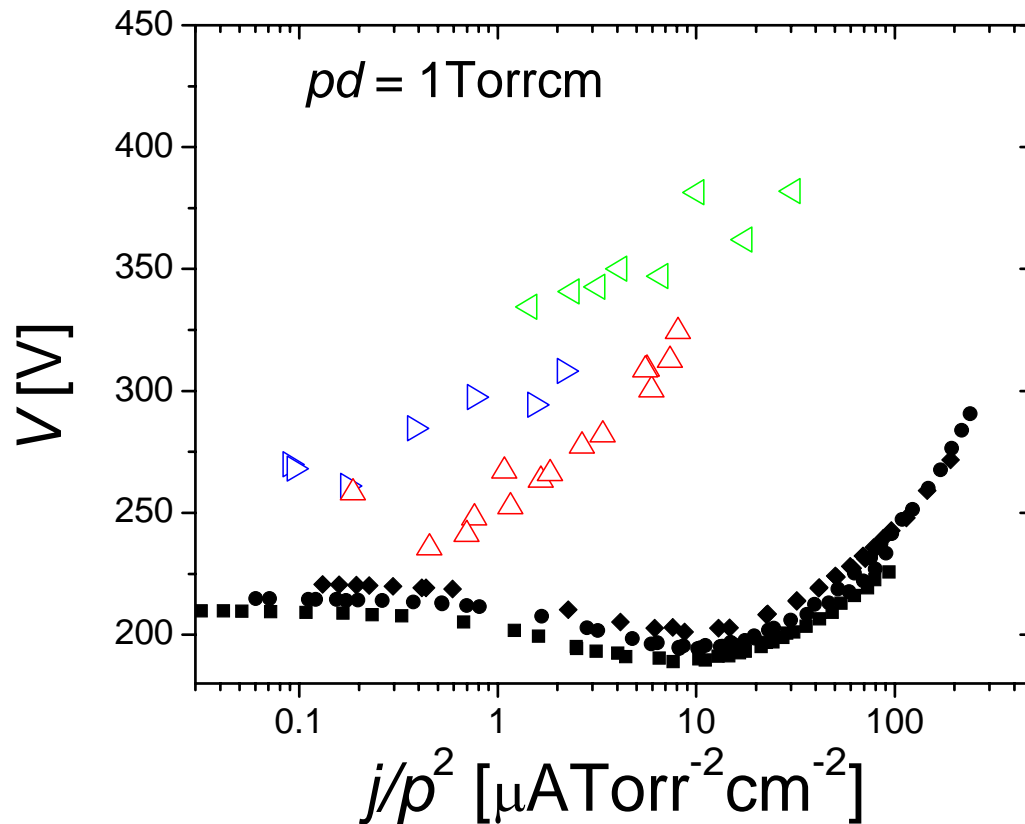

- $d = 1 \text{ cm}, p = 1 \text{ Torr}, D = 5.4 \text{ cm}$
- $d = 2 \text{ cm}, p = 0.5 \text{ Torr}, D = 5.4 \text{ cm}$
- ◆ $d = 3 \text{ cm}, p = 0.3 \text{ Torr}, D = 5.4 \text{ cm}$

- ▷ $d = 50 \mu\text{m}, p = 220 \text{ Torr}, D = 2 \text{ mm}$
- △ $d = 100 \mu\text{m}, p = 111 \text{ Torr}, D = 2 \text{ mm}$
- ◁ $d = 200 \mu\text{m}, p = 55 \text{ Torr}, D = 2 \text{ mm}$



Constricted regime of discharge

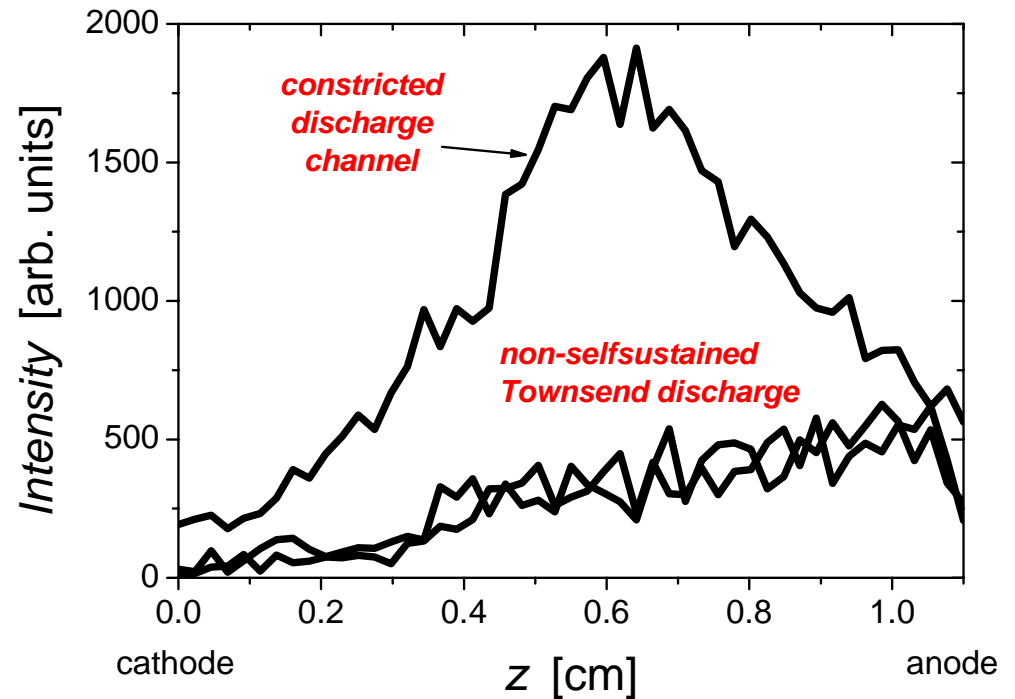
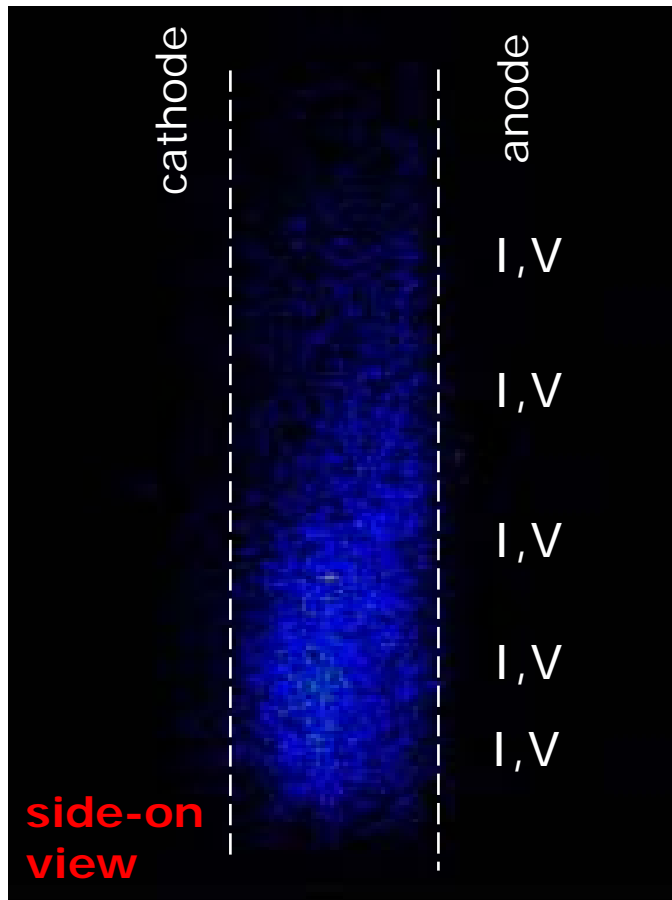

Volt-Ampere characteristics

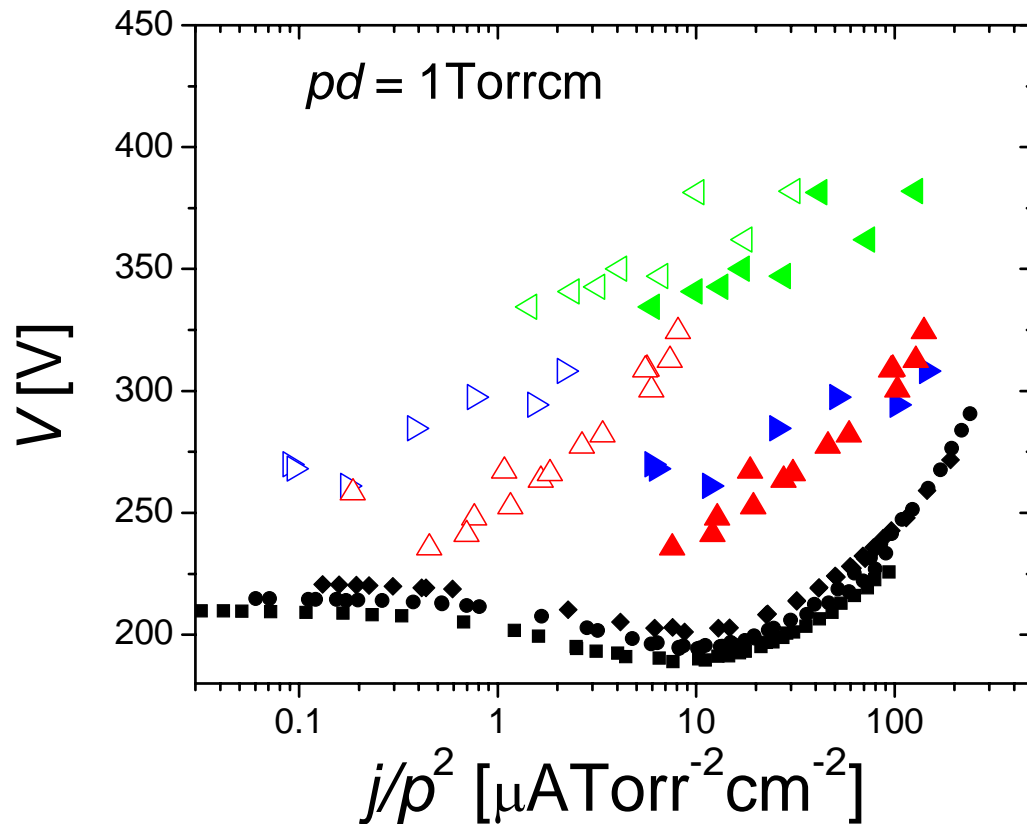

- $d = 1 \text{ cm}, p = 1 \text{ Torr}, D = 5.4 \text{ cm}$
- $d = 2 \text{ cm}, p = 0.5 \text{ Torr}, D = 5.4 \text{ cm}$
- ◆ $d = 3 \text{ cm}, p = 0.3 \text{ Torr}, D = 5.4 \text{ cm}$

- ▶ $d = 50 \mu\text{m}, p = 220 \text{ Torr}, D_\mu = 0.24 \text{ mm}$
- ▲ $d = 100 \mu\text{m}, p = 111 \text{ Torr}, D_\mu = 0.49 \text{ mm}$
- ◀ $d = 200 \mu\text{m}, p = 55 \text{ Torr}, D_\mu = 0.98 \text{ mm}$

open symbols - $D = 2 \text{ mm}$
solid symbols - scaled by D_μ



Oscillations

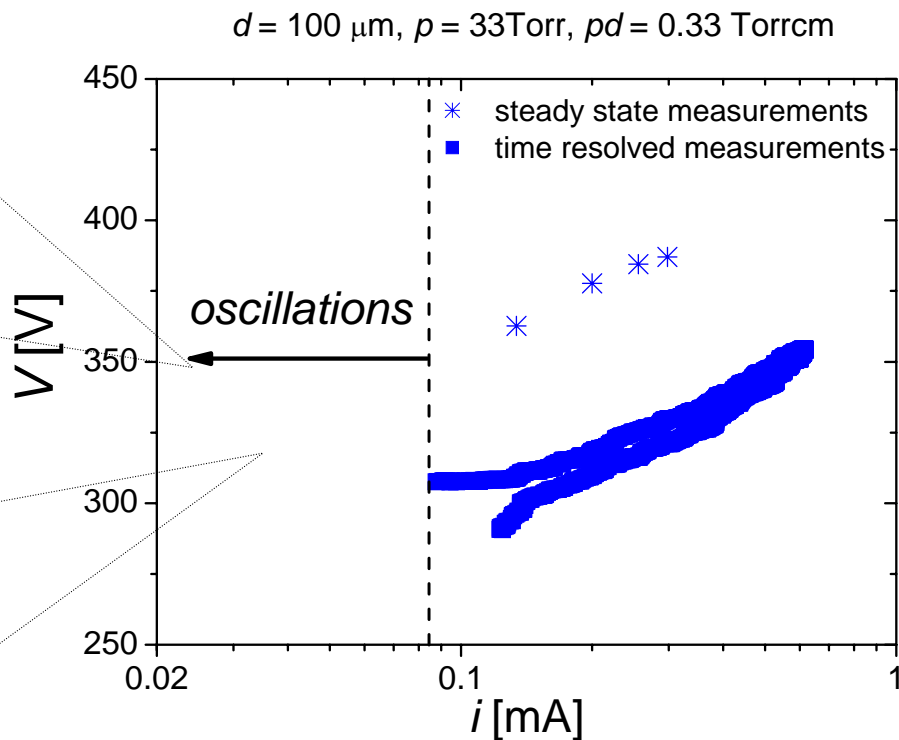
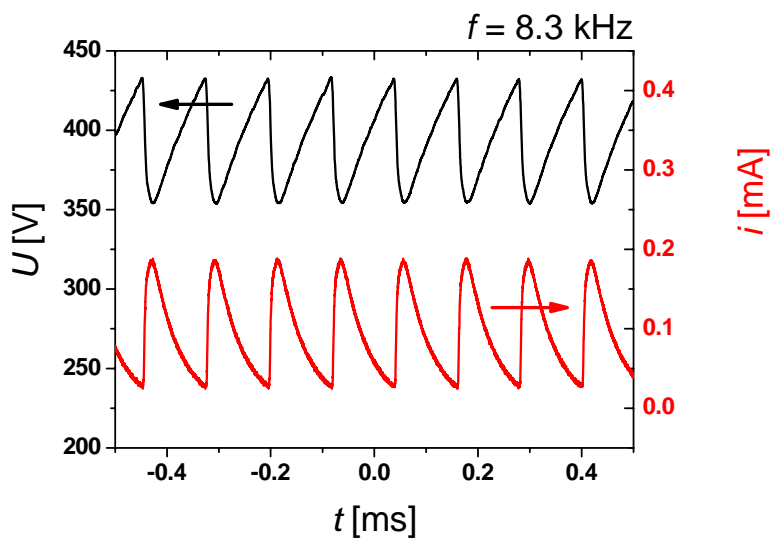
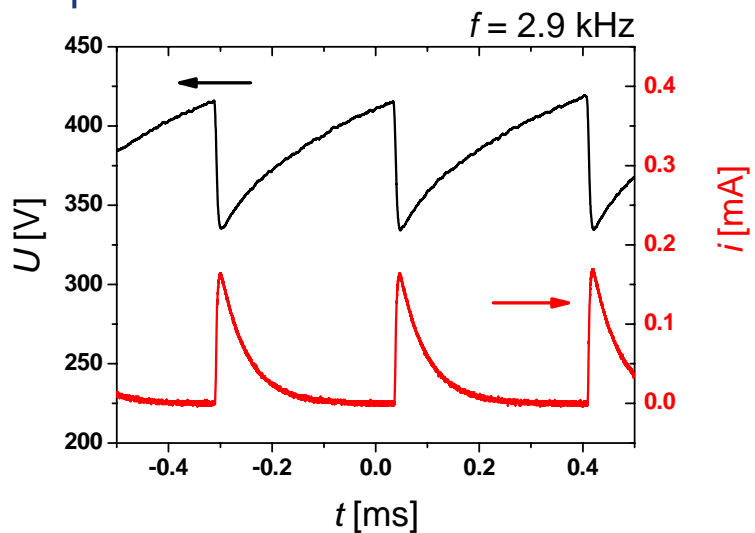

Oscillations

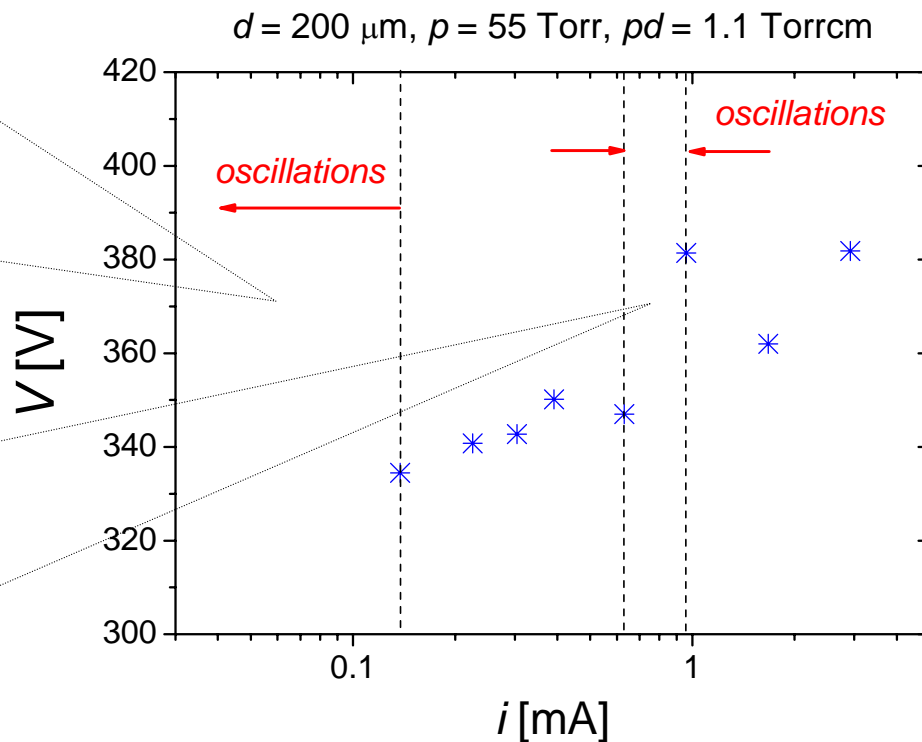
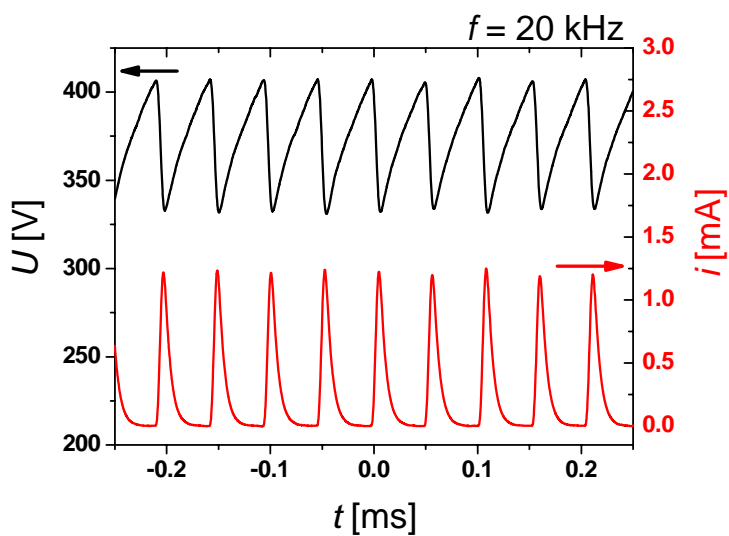
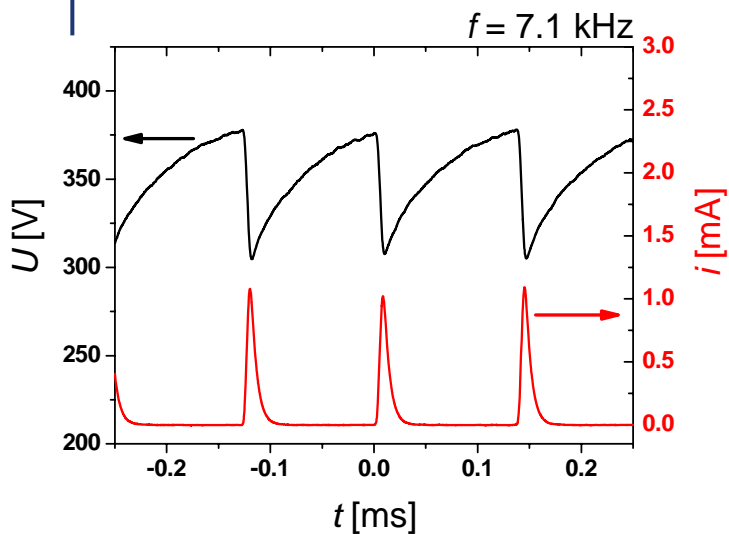

The Story so far..

- We were not able to operate in the Townsend regime, which may be optimal for some applications
- pd scaling is not applicable at gap spacing of less than 5 micrometers;
- For micron and sub-micron gaps modified Paschen curve should be used;
- The incorporation of field emissions leads to deviations from the well-known Paschen curve in small gaps;
- It appears that j/p^2 scaling is maintained if we assume that the width of the conducting channel is limited by diffusion;
- In other words the discharges seem to be constricted or limited by geometry and it is essential to record the spatial profiles of emission for such discharges
- Paschen curve may show features to the left of the minimum that appear like those due to field emission but those are due to the long path breakdown .
- Several modes of oscillations occur for different current densities.

